

Modular Short Taper Adapter BT as per ISO 7388-2 (JIS B6339), Form JD

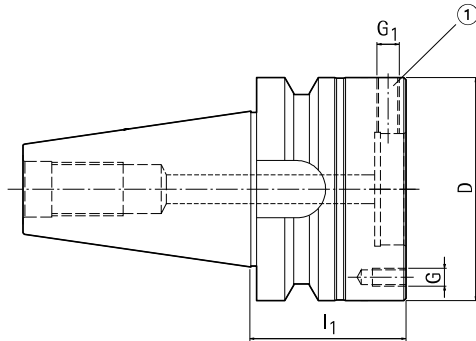

Nominal size BT	Dimensions					Order designation	Order No.
	D	l ₁	G	G ₁	Weight [kg]		
30	60	40	M5	M8x1	0,7	22.150.30.60.Z	30584725
30	70	40	M6	M8x1	0,8	22.150.30.70.Z	30584726
40	60	55	M5	M8x1	1,5	22.150.40.60.Z	30584734
40	70	55	M6	M8x1	1,6	22.150.40.70.Z	30584736
40	80	65	M6	M8x1	2	22.150.40.80.Z	30584751
40	100	70	M8	M10x1	2,6	22.150.40.100.Z	30584752
45	60	65	M5	M8x1	3	22.150.45.60.Z	30584755
45	70	65	M6	M8x1	3,1	22.150.45.70.Z	30584756
45	80	65	M6	M8x1	3,3	22.150.45.80.Z	30584757
45	100	75	M8	M10x1	3,5	22.150.45.100.Z	30584760
45	117	75	M8	M10x1	4,4	22.150.45.117.Z	30584762
50	60	70	M5	M8x1	4,8	22.150.50.60.Z	30584764
50	70	70	M6	M8x1	4,9	22.150.50.70.Z	30584765
50	80	70	M6	M8x1	5,1	22.150.50.80.Z	30584767
50	100	70	M8	M10x1	5,3	22.150.50.100.Z	30584769
50	117	80	M8	M10x1	6,3	22.150.50.117.Z	30584770
50	140	80	M10	M10x1	6,6	22.150.50.140.Z	30584772

Spare parts: Grub Screw for Modular Short Taper Adapter as per ISO 7388-2 (JIS B6339), Form JD

Module diameter D	Quantity required	① Grub Screw			
		Weight [kg]	Size	Order designation	Order No.
60-80	4	0,001	M8x1x16	89.122.685	10075355
100-140	4	0,001	M10x1x20	89.122.684	10075099

Usage: For use in the machine spindle for mounting KS flange adapters, shrink chucks, hydraulic chucks, chucks for cylindrical shanks or tools with a modular shank in accordance with WTE works standard.

Supply includes: Complete with threaded pins for aligning the radial run-out, does not include pull stud.

Design: Due to threaded pins the radial run-out of a connection or tool fitted can be adjusted exactly in relation to the steep taper.

Dimensions in mm.

Spare parts and accessories at the end of this chapter.

Version with face connection on request. Custom designs available on request.

