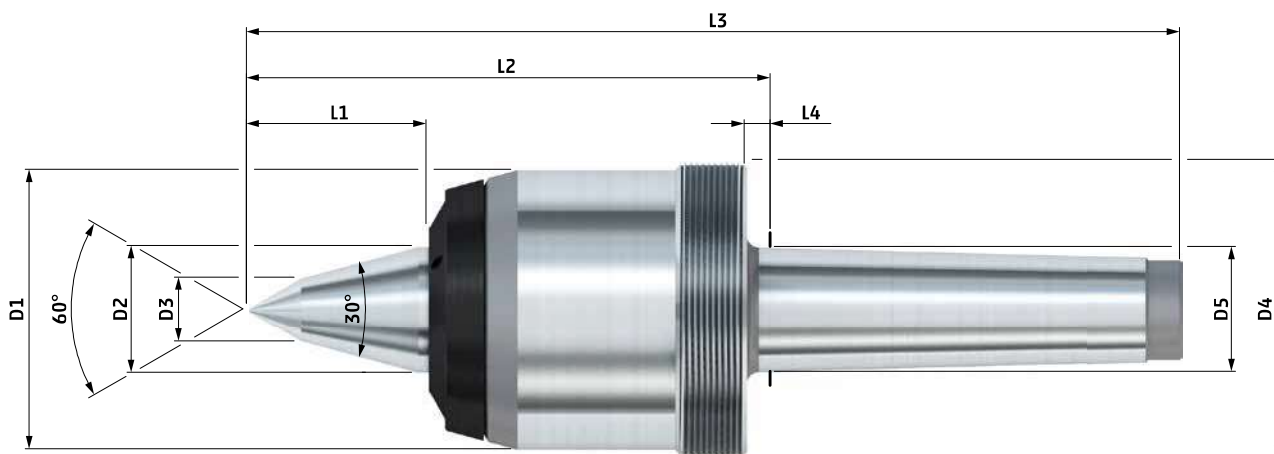

Technical data – type RNC with morse taper

type tool steel tip

**WITH TOOL STEEL TIP****TYPE
TURNING****TYPE
GRINDING**

type RNC	MK	D1	D2	D3	D4	D5	L1	L2	L3	L4	rpm max. [1/min]	cat. no.	cat. no.
3	3	55	22	10	M58 x 1.5	23.83	32	108	189	5	8000	813 01	813 0102
	4	55	22	10	M58 x 1.5	31.27	32	109.5	212	6.5	8000	813 02	813 0202
	5	55	22	10	M58 x 1.5	44.4	32	109.5	239	6.5	8000	813 03	813 0302
4	4	70	32	16	M75 x 1.5	31.27	45	131.2	233.7	6.5	7000	813 04	813 0402
	5	70	32	16	M75 x 1.5	44.4	45	131.2	260.7	6.5	7000	813 05	813 0502
5	5	92	45	22	M95 x 2	44.4	62	158.2	287.7	6.5	5000	813 06	813 0602
	6	92	45	22	M95 x 2	63.35	62	159.7	341.7	8	5000	813 07	813 0702
6	6	107	55	28	M110 x 2	63.35	72	181.7	363.7	8	3000	813 08	813 0802

- Run-out deviation max.: type turning 0.005 mm · type grinding 0.003 mm.
- Extracting nuts and extracting disks see page 118 - 119 for accessories.
- Load chart see page 102.