

FH

BAH

TA.CP

TA

MOX

HT

4-15

VH

TSI/TSX

T

MT-TC-TC3



TAR04.P

TESTA AD ANGOLO - ANGLE HEAD

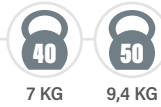
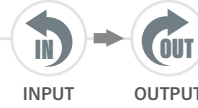
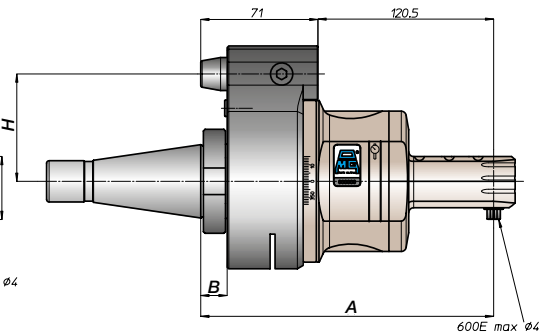
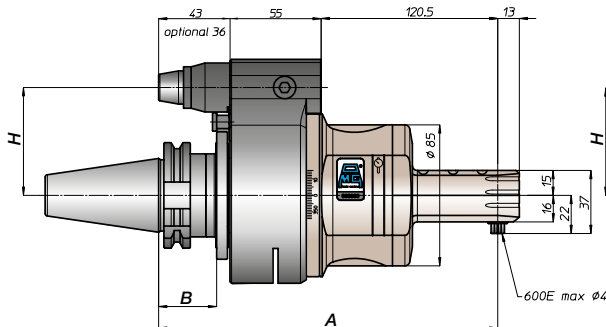
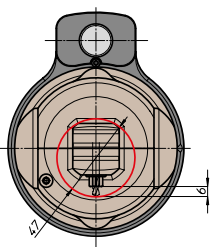
PESO
WEIGHTROTAZIONE
ROTATIONCARATTERISTICHE
FEATURESCONO
SHANK

DIN69871



ANSIB5.50



BT



HSK

DIN69893

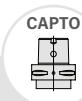

CAPTO

ISO26623

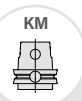

KM



DIN2080



ANSIB5.18

SIZE

30 40 45 50 40 50 40 50 63 80 100

C5 C6 C8

63 80 100

40 50 40 50

A

218,5 218,5 218,5 226,5 227,5 222,5 218,5 188,5 191,5 188,5 191,5

B

35 35 35 45 44 46 39 41 13 16 13 16

H STANDARD

65 80 65 80 65 80 65 80 65 80 65 80 65 80

H OPTIONAL

110 110 110 110 110 110 110 110

For DIN69871, ANSIB5.50 and BT, dual contact as option



TAR04.P-L90

ROTAZIONE
ROTATION

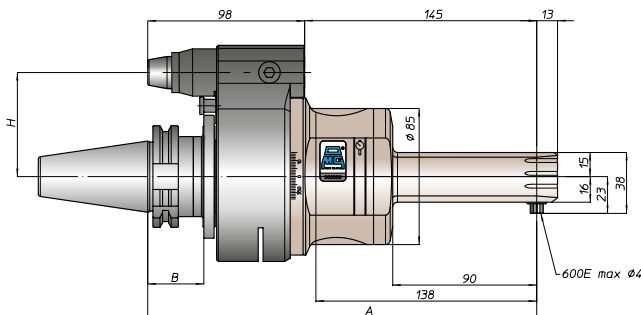

CONO SHANK	DIN69871				CAT ANSIB5.50		BT		HSK DIN69893			CAPTO ISO26623			KM			DIN2080		NMTB ANSIB5.18	
SIZE	30	40	45	50	40	50	40	50	63	80	100	C5	C6	C8	63	80	100	40	50	40	50
A	257				257		257	265	266			261			257			227	230	227	230

TAR04.P-L109

ROTAZIONE
ROTATION

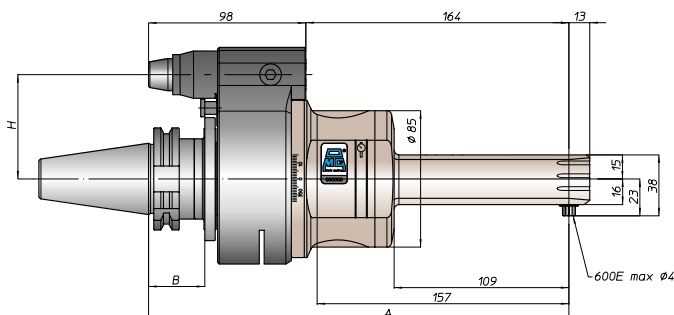

CONO SHANK	DIN69871				CAT ANSIB5.50		BT		HSK DIN69893			CAPTO ISO26623			KM			DIN2080		NMTB ANSIB5.18	
SIZE	30	40	45	50	40	50	40	50	63	80	100	C5	C6	C8	63	80	100	40	50	40	50
A	276				276		276	284	285			280			276			246	249	246	249

TAR04.P-L128

ROTAZIONE
ROTATION

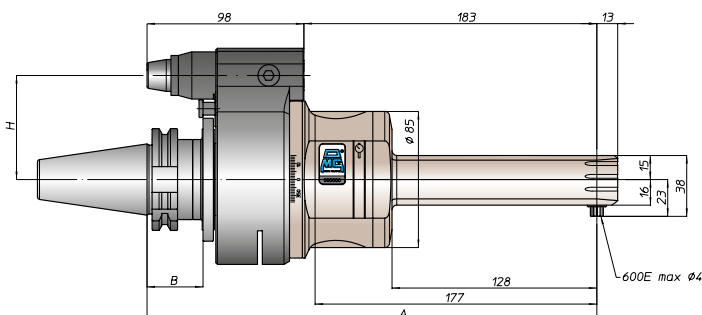
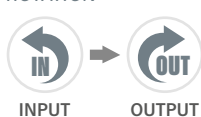

CONO SHANK	DIN69871				CAT ANSIB5.50		BT		HSK DIN69893			CAPTO ISO26623			KM			DIN2080		NMTB ANSIB5.18	
SIZE	30	40	45	50	40	50	40	50	63	80	100	C5	C6	C8	63	80	100	40	50	40	50
A	295				295		295	303	304			299			295			265	268	265	268

TAR04.P-L147

ROTAZIONE
ROTATION

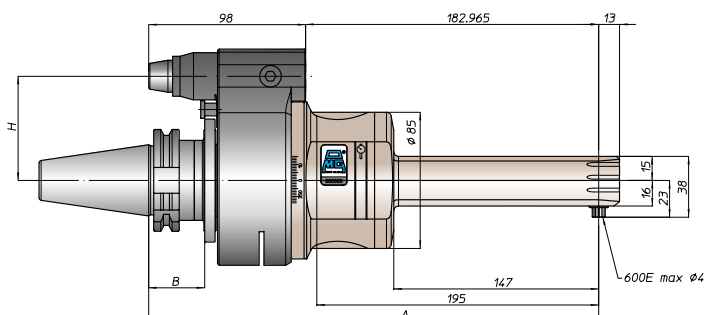

CONO SHANK	DIN69871				CAT ANSIB5.50		BT		HSK DIN69893			CAPTO ISO26623			KM			DIN2080		NMTB ANSIB5.18	
SIZE	30	40	45	50	40	50	40	50	63	80	100	C5	C6	C8	63	80	100	40	50	40	50
A	314				314		314	322	323			318			314			284	287	284	287